

HD 18" Tube Step Installation Instructions

Part No's: 301850 / 301851



Quality and Style that Endures

Follow the diagram and the written directions carefully for a proper, safe installation.

Should you encounter an unusual, unforeseen problem, contact our Technical Help Line
7:00 AM – 3:00 PM Pacific Time

(951) 719-1068

Visit our web-site at

www.CARR.com

Carr Pattern Co., Inc.

Vehicle Application:

JEEP

'97-'06 TJ Wrangler

MATERIAL NEEDED:

Drill motor, 3/8" drill bit, 1/8" drill bit, 1/4" drill bit, pencil, Phillips screw driver, center punch, two 1/2" wrenches, two 7/16" wrenches, and silicone.

MATERIAL FURNISHED:

Two 18" tubes, four black mounting castings, four zinc plated steel brackets, instruction page and two hardware packs (**Important! Not all of the parts in these hardware packs may be needed for proper installation.**)

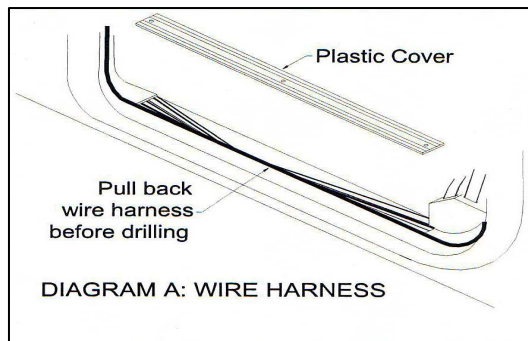
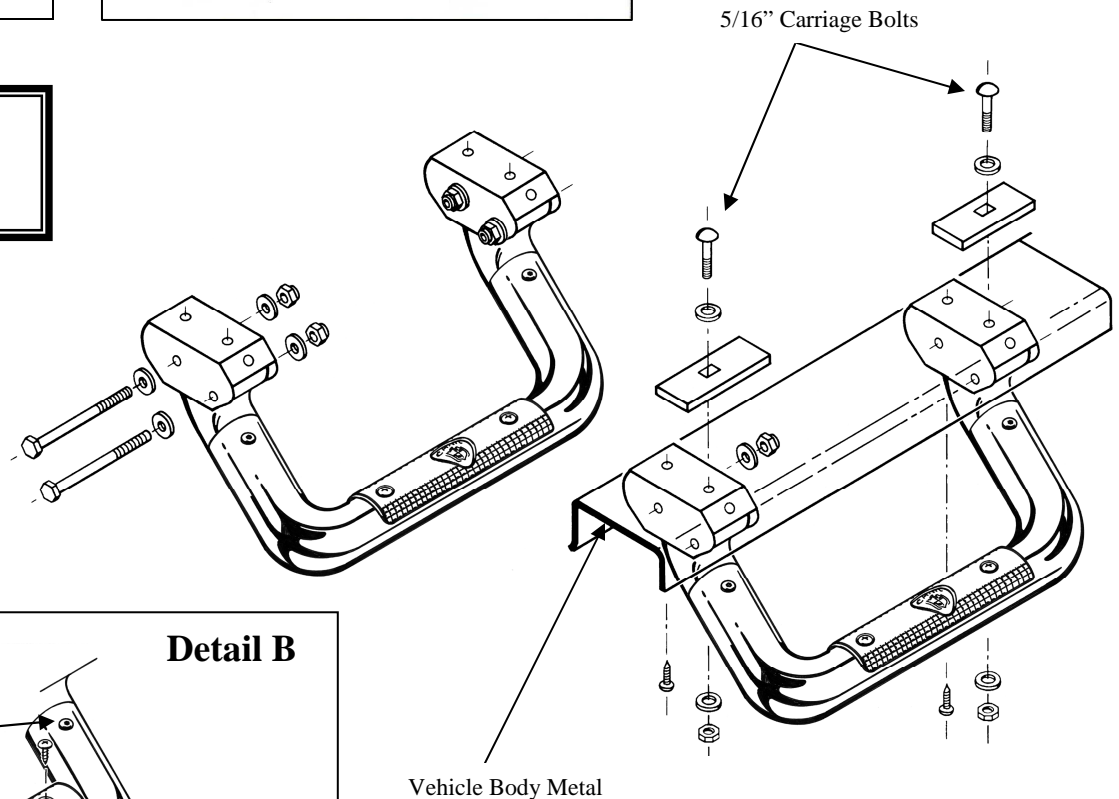
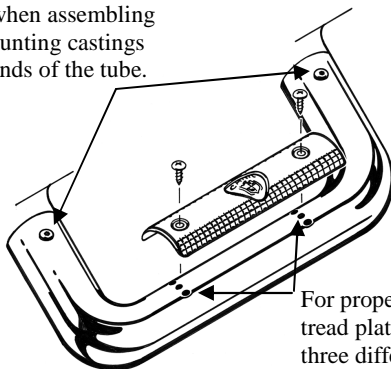

DIAGRAM A: WIRE HARNESS

WAX YOUR STEP ON A REGULAR BASIS TO MAINTAIN ITS LUSTER



Use the 5/16 X 2 1/2" Button Head Bolts when assembling the black mounting castings to the open ends of the tube.



Detail B

For proper alignment, the tread plate can be rotated in three different positions.



HD 18" Tube Step Installation Instructions

Part No's: 301850 / 301851



WARNINGS!

- ✓ Do not over tighten the nuts and bolts or damage to the castings and or stripping of the threads could result.
- ✓ FOR SAFE AND PROPER USAGE OF THIS PRODUCT, THE MOUNTING INSTRUCTIONS MUST BE FOLLOWED CAREFULLY AND COMPLETELY.
- ✓ The manufacturer and distributor of this product are in no way responsible for the consumer's failure to adhere to the warnings and directions of these instructions in the event of damage to the consumer's vehicle, other properties and or personal injury.
- ✓ **REFER TO DIAGRAM "A" WIRE HARNESS. STEP "8" ON THIS PAGE MUST BE FOLLOWED, IF NOT ELECTRICAL DAMAGE TO YOUR VEHICLE MAY OCCUR.**

1. Place the black mounting castings in the open ends of the tube. Line up the holes and securely fasten the castings to the tube with hardware provided. See **Detail B**.
2. For the proper position of the step, the front edge of the seat while in normal driving position should be in line with the center of the step. For personal preference or to avoid any obstruction underneath body metal, step can be moved left or right.
3. Assemble the steel brackets to the black mounting castings that are bolted to the tube as shown in the diagram, but only hand-tighten.
4. When positioning the step against the body metal be sure to avoid all bumps and screws to make sure that the step is against a flat surface.
5. When the desired location is found, while holding the step in that position, take a pencil and mark around the zinc plated steel mounting brackets and mark the 1/4" hole at the back of each bracket.
6. Remove the zinc plated steel mounting brackets from the black mounting castings and place them back into the same place where you marked around these brackets and marked the 1/4" hole.
7. While holding the above bracket in this position, mark the 5/16" hole at the other end of the bracket on the body metal (not the center larger 1/2" hole).
8. Center-punch the 5/16" and the 1/4" marked holes for each bracket.
9. ***REFER TO DIAGRAM "A" WIRE HARNESS.** Remove the plastic cover that is holding the carpet down and move the wire harness out of the way before drilling out the hole for the next step as shown on the diagram. Do this procedure for both sides of your vehicle, because the wire harness may be on either side.
10. Take a 1/8" drill bit and drill out the centered punched holes.
11. Replace the 1/8" drill bit and drill out the 1/8" hole for the marked 5/16" hole with a 3/8" drill bit.
12. After drilling, make sure that all the burrs are removed.
13. Place the steel brackets back on the vehicle where the holes were drilled.
14. Use the 5/16" x 1" Carriage bolts to go through two 2 1/2" rectangular washers and the 3/8" holes in the body metal and securely tighten the brackets to the vehicle. (See Diagram)
15. Take the 5/8" sheet metal screws provided and securely tighten the brackets using the 1/8" drilled hole where the 1/4" marked hole was.
16. Re-install your carpet protectors with the screws that were removed.
17. Place the black mounting castings back into the mounted steel brackets with the 1/4" hardware provided and securely tighten.
18. Check again and securely tighten ALL hardware.
19. We advise putting silicone sealer around the areas where the zinc plated steel mounting brackets contact the body metal.
20. After one month of use, go back and give all the hardware a final tightening.

Carr Pattern Co., Inc. Warranty Policy

Finishes: Limited Lifetime

Structural Warranty: Limited Lifetime

Warranty Conditions:

- a. All warranties start from consumer's date of purchase.
- b. A new product will be sent out immediately to replace a warranty claim.
- c. The above guidelines apply only to the Original Purchaser.
- d. Original proof of purchase must be submitted for all warranty and returns issues.

Warranty Limitations:

- a. Warranty coverage extends ONLY to repair or replacement of the CARR product. This warranty does not cover the cost of labor, transportation, installation or removal of the product.
- b. Warranty coverage does not extend to damage caused by: collision, fire, theft, freezing, vandalism, riot, explosion or object striking the product, or misuse of the product and/or the vehicle on which the product is being installed.
- c. Warranty coverage does not extend to damage caused by: airborne fallout (chemicals, tree sap, etc.), stones, hail, earthquake, water or flood, windstorm, lightning, the application of chemicals or sealants subsequent to manufacture.
- d. Warranty coverage does not extend to damages caused by: normal wear and tear, abuse, modification or improper installation of the product.
- e. Warranty coverage does not extend to any economic loss or extra expense including (without limitation), payment for the loss of time or pay, inconvenience, storage, loss of vehicle use, vehicle rental expense, equipment rental expense, lodging, meals, or other travel costs.

Other Terms:

This warranty gives you specific legal rights and you may also have other rights that vary from state to state. CARR does not authorize any person to create for it any other obligation or liability in connection with its products. ANY IMPLIED WARRANTY OF MERCHANTABILITY OR FITNESS FOR A PARTICULAR PURPOSE APPLICABLE TO THIS PRODUCT IS LIMITED IN DURATION TO THE DURATION OF THIS WRITTEN WARRANTY. PERFORMANCE OF REPAIRS AND NEEDED ADJUSTMENTS IS THE EXCLUSIVE REMEDY UNDER THIS WRITTEN WARRANTY OR ANY IMPLIED WARRANTY. CARR SHALL NOT BE LIABLE FOR INCIDENTAL OR CONSEQUENTIAL DAMAGES RESULTING FROM BREACH OF THIS WRITTEN WARRANTY.*

*Some states do not allow limitations on how long an implied warranty will last or the exclusion or limitation of incidental or consequential damages, so that above limitations or exclusions may not apply to you.

Guarantee: Every attempt has been made to manufacture and distribute the finest quality products available. Our manufactured products are guaranteed to be free of defects due to workmanship or materials. Distributed products are subject to manufacturer's warranty only.