

HD 18" Tube Step Installation Instructions

Part No's: 301840 / 301841

WARNINGS!

- ✓ Do not over tighten the nuts and bolts or damage to the castings and or stripping of the threads could result.
- ✓ FOR SAFE AND PROPER USAGE OF THIS PRODUCT, THE MOUNTING INSTRUCTIONS MUST BE FOLLOWED CAREFULLY AND COMPLETELY.
- ✓ The manufacturer and distributor of this product are in no way responsible for the consumer's failure to adhere to the warnings and directions of these instructions in the event of damage to the consumer's vehicle, other properties and or personal injury.

Materials Furnished:

Two 18" tubes, four black mounting castings, four steel mounting brackets, instruction sheet and two hardware packs (**Important! Not all of the parts in these hardware packs may be needed for proper installation**).

Tools Needed:

One Phillips Screwdriver, two 1/2" open or box wrenches, pencil, center punch, drill motor, sharp 1/8" drill bit, sharp 5/16" drill bit.

1. These steps mount to an extremely strong part of your vehicle, the back side of its rocker panels. For the proper position of the step, the front edge of the seat while in normal driving position should be in line with the center of the step. For personal preference or to avoid any obstruction that may be on the backside of the rocker panel, the step can be moved towards the front or the rear of the vehicle.
2. Place the black mounting castings in the open ends of the tube. Line up the holes and securely fasten the castings to the tube with hardware provided. See upper portion of **Detail A**.
3. Assemble the steel mounting brackets to the step as shown in the drawing, but only hand tighten.
4. When positioning the assembled step against the back side of the rocker panel, be sure to avoid all bumps and screws to ensure that the step is against a flat surface. Take a pencil and mark a vertical line that lines up with the front edge of the seat, on the outside painted surface of the pinch weld. (See diagram). Disassemble the brackets from the step.
5. Measure 8" on each side of the marked vertical line and mark two more lines on that same surface. The dimension between the two outside marked lines should be 16".
6. Measure 3/8" from the edge of the pinch weld where you marked the other vertical lines and mark two horizontal lines, creating a cross hair. **NOTE: DOUBLE CHECK DIMENSIONS BEFORE DRILLING!** (Warning: when drilling holes leave at least 1/8" of metal between the hole and the edge of the pinch weld).
7. Take a center punch and punch the center where the two sets of lines cross.
8. Take a 1/8" drill bit and drill out the centered punched holes.
9. Enlarge the 1/8" hole with a 5/16" drill bit.
10. After drilling make sure that all the burrs are removed.
11. Now you will need to bend the tab on the back of each bracket as shown on the diagram to conform to the body metal of your vehicle.
12. Once the tabs are bent to the correct angle, use the 5/16" x 5/8" hex bolts with the 5/16" hex nuts and 5/16" washers to securely tighten the brackets on the vehicle.
13. Using the top 1/4" hole at the top of each steel mounting bracket, take a 1/8" drill bit and drill holes into the body metal. Take the 5/8" sheet metal screws provided and securely tighten. (Drilling at an angle may be necessary due to interference or for proper alignment). Place the step back into the brackets and securely tighten.
14. We advise putting silicone sealer around the areas where the steel mounting brackets contact the body metal.
15. After one month of use, go back and give all hardware a final tightening.



Quality and Style that Endures

Follow the diagram and the written directions carefully for a proper, safe installation.

Should you encounter an unusual, unforeseen problem, contact our Technical Help Line

7:00 AM – 3:00 PM Pacific Time
(951) 719-1068

Visit our web-site at

www.CARR.com

Carr Pattern Co., Inc. Warranty Policy

Finishes: Limited Lifetime

Structural Warranty: Limited Lifetime

Warranty Conditions:

- a. All warranties start from consumer's date of purchase.
- b. A new product will be sent out immediately to replace a warranty claim.
- c. The above guidelines apply only to the Original Purchaser.
- d. Original proof of purchase must be submitted for all warranty and returns issues.

Warranty Limitations:

- a. Warranty coverage extends ONLY to repair or replacement of the CARR product. This warranty does not cover the cost of labor, transportation, installation or removal of the product.
- b. Warranty coverage does not extend to damage caused by: collision, fire, theft, freezing, vandalism, riot, explosion or object striking the product, or misuse of the product and/or the vehicle on which the product is being installed.
- c. Warranty coverage does not extend to damage caused by: airborne fallout (chemicals, tree sap, etc.), stones, hail, earthquake, water or flood, windstorm, lightning, the application of chemicals or sealants subsequent to manufacture.
- d. Warranty coverage does not extend to damages caused by: normal wear and tear, abuse, modification or improper installation of the product.
- e. Warranty coverage does not extend to any economic loss or extra expense including (without limitation), payment for the loss of time or pay, inconvenience, storage, loss of vehicle use, vehicle rental expense, equipment rental expense, lodging, meals, or other travel costs.

Other Terms:

This warranty gives you specific legal rights and you may also have other rights that vary from state to state. CARR does not authorize any person to create for it any other obligation or liability in connection with its products. ANY IMPLIED WARRANTY OF MERCHANTABILITY OR FITNESS FOR A PARTICULAR PURPOSE APPLICABLE TO THIS PRODUCT IS LIMITED IN DURATION TO THE DURATION OF THIS WRITTEN WARRANTY. PERFORMANCE OF REPAIRS AND NEEDED ADJUSTMENTS IS THE EXCLUSIVE REMEDY UNDER THIS WRITTEN WARRANTY OR ANY IMPLIED WARRANTY. CARR SHALL NOT BE LIABLE FOR INCIDENTAL OR CONSEQUENTIAL DAMAGES RESULTING FROM BREACH OF THIS WRITTEN WARRANTY.*

*Some states do not allow limitations on how long an implied warranty will last or the exclusion or limitation of incidental or consequential damages, so that above limitations or exclusions may not apply to you.

Guarantee: Every attempt has been made to manufacture and distribute the finest quality products available. Our manufactured products are guaranteed to be free of defects due to workmanship or materials. Distributed products are subject to manufacturer's warranty only.

CARR • 27447 Bostik Court • Temecula CA 92590

FRONT DOOR VIEW
('05-'09 Tacoma shown)

HD 18" Tube Step Installation Instructions

Part No's: 301840 / 301841

REAR DOOR VIEW
('05-'09 Tacoma shown)

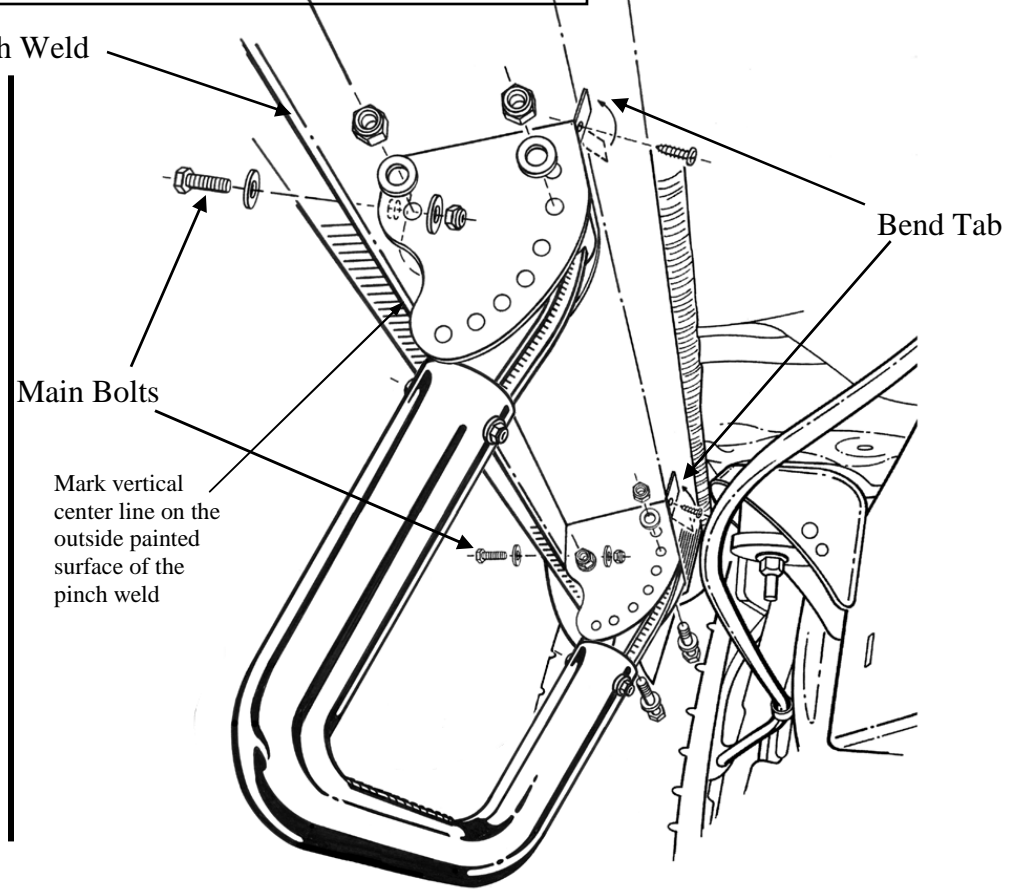
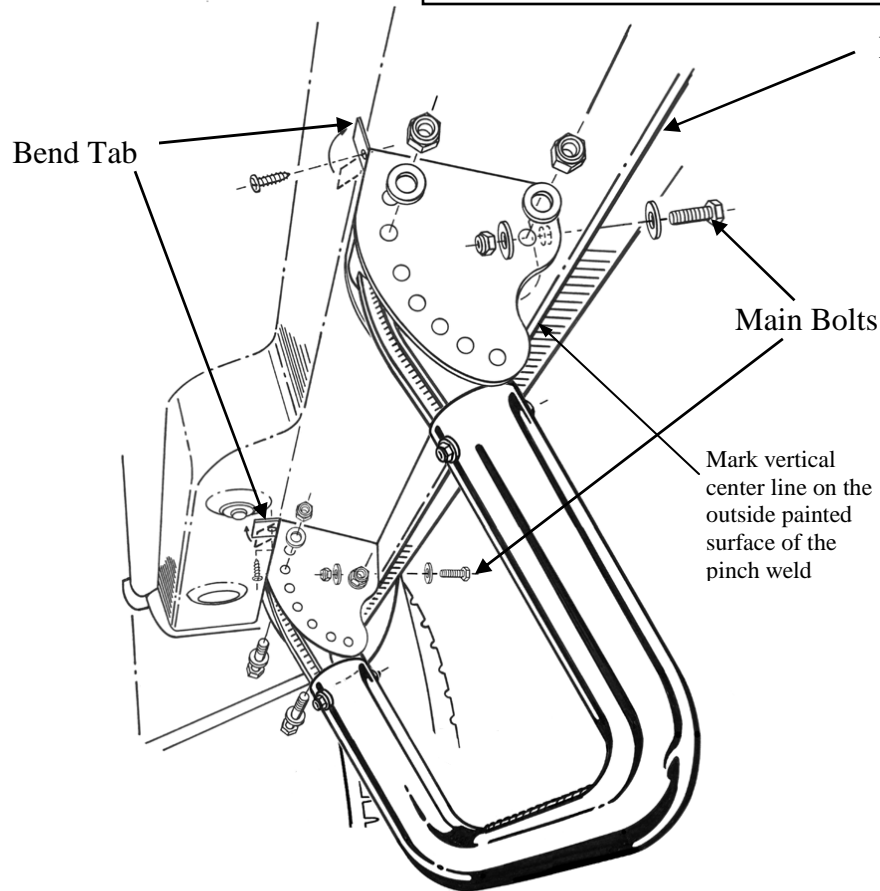

Use the 5/16 X 2 1/2" Button Head bolts when assembling the black mounting castings to the open ends of the tube.

Detail A

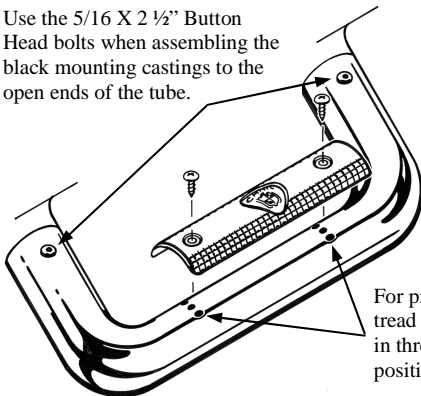

For proper alignment, the tread plate can be rotated in three different positions.

Diagrams above show passenger side of vehicle

Part numbers 301840 / 301841 fits the following vehicles:

JEEP

'02-'13 KJ Liberty (CAUTION: Ground clearance problem on stock vehicle)

TOYOTA

'05-'13 Tacoma all cabs all doors/Prerunner/4Runner

'00-'13 Toyota Tundra

'01-'07 Toyota Sequoia

'07-'13 FJ Cruiser

WAX YOUR STEP ON A REGULAR BASIS TO MAINTAIN ITS LUSTER