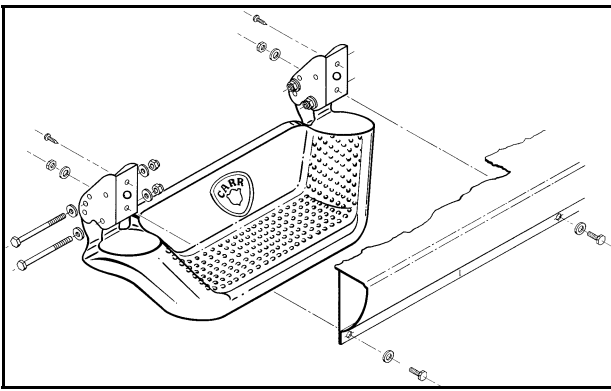
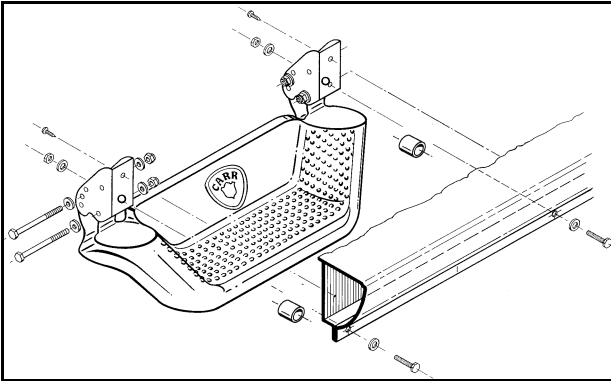

**A**

Applications for  
Diagram "A"

**DODGE**  
74-93 F/S PU  
97-06 Dakota  
**NISSAN**  
98-06 Frontier Reg Cab  
02-06 Frontier Crew Cab  
00-06 Xterra front doors

**B**

Applications for  
Diagram "B"

**DODGE**  
02-06 1500/2500/3500  
Ram PU Full Size  
02-06 Quad Cab All Drs

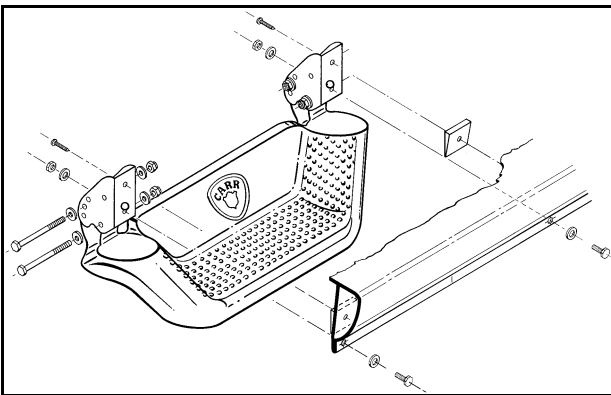
**C**

Applications for  
Diagram "C"

**DODGE**  
"Old body style"  
94-02 Full size 2500/3500  
Ram PU Reg.Cab  
94-02 Quad Cab 1500  
98-02 Quad Cab all Drs  
2500/3500 Ram

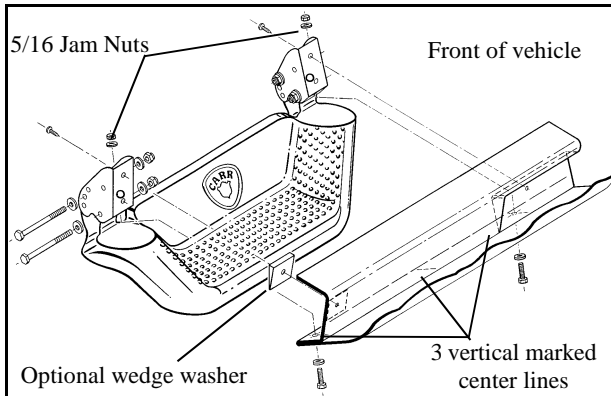
**D**

Applications for  
Diagrams "D"

**FORD**  
01-03 Super Crew  
97-04 F150 PU Heritage  
97-03 F150 Quad Cab  
97-06 Expedition

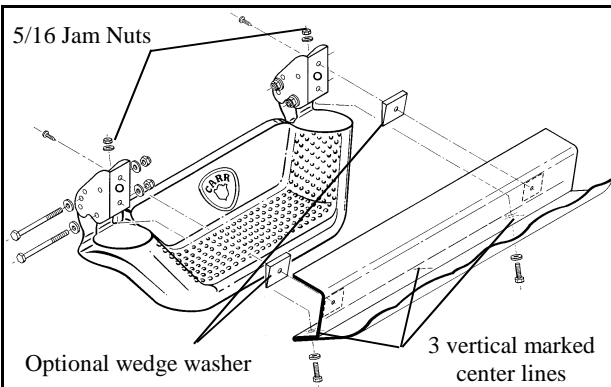
**E**

Applications for  
Diagram "E"

**CHEVY/GMC**  
02-06 Denali Truck  
88-06 F/S PU  
86-06 F/S Crew Cab  
02-06 Avalanche  
88-06 Sierra/Silverado1500  
01-06 Sierra/Silverado 2500  
3500 C&K PU  
**FORD**  
04-06 F-150 New Body

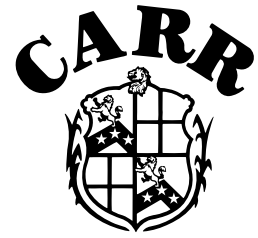

**INSTALLATIONS INSTRUCTION  
FOR  
P/N 147022 & 147021**



*Quality and Style that Endures*

**Locate the correct  
diagram and follow the  
written directions on the  
back carefully for a  
proper, safe  
installations.**

**Should you encounter an  
unusual, unforeseen  
problem, contact our  
Technical Help Line  
7:00 AM - 3:00 PM**

**Pacific Time  
(951) 719-1068**

**[www.CARR.com](http://www.CARR.com)**

**©CARR PATTERN CO.,  
INC.**

**WAX YOUR STEP  
ON A REGULAR  
BASIS TO  
MAINTAIN ITS  
LUSTER!**

# GX2 MULTI-MOUNT STEP INSTALLATION INSTRUCTIONS

PART NO'S: 147022 & 147021

**WARNING:** Do not over tighten nuts and bolts, or damage to the casting and or stripping of the threads could result.  
**WARNING:** FOR SAFE AND PROPER USAGE OF THIS PRODUCT, THE MOUNTING INSTRUCTIONS MUST BE FOLLOWED CAREFULLY AND COMPLETELY.  
**IMPORTANT:** The manufacturer and distributor of this product are in no way responsible for the consumer's failure to adhere to the warnings and directions of these instructions, in the event of damage to the consumer's vehicle, other properties and or personal injury.

**MATERIALS NEEDED:** Drill motor, 3/8" drill bit, 1/4" drill bit, 1/8" drill bit, pencil, Phillips screw driver, center punch, two 1/2" wrenches, two 7/16" wrenches, silicone.

**MATERIALS FURNISHED:**  
Two hardware packs, two step castings, four zinc plated steel brackets, instruction page.

**GX2**



- DIAGRAM'S A, B, C, D, E follow steps 1 & 2:** For the proper position of the step, the front edge of the seat while in normal driving position should be in line with the center of the step. For personal preference or to avoid any obstruction underneath body metal, step can be moved left or right.
- Assemble the steel brackets to the step as shown in the drawing, but only tighten with your fingers.
- DIAGRAM'S A, B, C, ONLY follow steps 3 - 19:** When positioning the step against the body metal be sure to avoid all bumps and screws to make sure that the step is against a flat surface.
- Hold the step on your vehicle where you will mount the step. Position the step so that the bottom of the mounting face of the bracket is at the bottom of the edge of the pinch weld. (See diagram). **DIAGRAM B:** Place the tube between the bracket and the body metal to fill in gap.
- While holding the step in that position, take a pencil and use the bottom 5/16" holes on each bracket as a guide and mark the holes on the inside of the body metal. **Do not use larger center hole.**
- Center punch the marked holes. **DIAGRAM B:** Center punch at the bend of the outer rocker panel and the pinch weld.
- Take a 1/8" drill bit and drill out the centered punched holes. **DIAGRAM B:** Drill the holes up against the bend of the rocker panel and the pinch weld.
- Replace the 1/8" drill bit and drill out the 1/8" hole with a 5/16" drill bit. (Warning: when drilling holes leave at least 1/8" of metal between the hole and the outside edge of the pinch weld). If the 5/16 flat washer does not fit on the outside pinch weld due to interference, do not use them.
- After drilling, make sure that all the burrs are removed.
- Remove the steel brackets from the step casting.
- Place the steel brackets back on the vehicle where the two holes were drilled. **DIAGRAM B:** Be sure to install the tubes.
- DIAGRAMS A, B, D, E:** Use the 5/16" x 5/8" bolts (**DIAGRAM B:** uses the 5/16" x 1 3/4" bolts) with the 5/16" hex nuts and 5/16" washers to securely tighten the brackets to the vehicle.
- DIAGRAM C:** Use the 5/16" x 5/8" bolts with the 5/16" hex nuts and 5/16" washers and hand tighten the brackets to the vehicle.
- Place the step back into the steel brackets with the 1/4" hardware provided and securely tighten, making sure that the proper hole selection has been made. (See diagram)
- DIAGRAMS A, B, D, E:** Using the two 1/4" holes at the top of the step, take a 1/8" drill bit and drill holes into the body metal. Take the 5/8" sheet metal screws provided and securely tighten. Drilling at an angle may be necessary due to interference or for proper alignment.
- DIAGRAM C:** Insert the wedge washers between the body metal and the brackets far enough so that the step is level. While holding the step in place, use the top 1/4" holes on each bracket and mark the holes on both wedge washers. Remove the wedge washer and drill it out with a 1/4" drill bit. Place the wedge washer back into place.. Take a 1/8" drill bit and drill through the holes in the bracket and the holes in the wedge washer into the body metal. Use the longer sheet metal screws and place it through the bracket and the hole in the wedge washer and securely tighten it to the vehicle. Remove the step once again from the brackets. Now securely tighten the brackets to the vehicle. Place the steps back into the brackets and securely tighten.
- DIAGRAMS A, B, C, D, E follow steps 17-19:** Check again and securely tighten ALL hardware.
- We advise putting silicone sealer around the areas where the aluminum mounting brackets contact the body metal.
- After one month of use, go back and give all hardware a final tightening.
- DIAGRAM'S D & E ONLY follow steps 20 - 25:** When positioning the step against the body metal be sure to avoid all bumps and screws to make sure that the step is against a flat surface. Take a pencil and mark a vertical line that lines up with the front edge of the seat, on the double body metal area of your rocker panel. (See Diagram) **Do not use larger center hole.**
- DIAGRAM D ONLY:** Ford application will need the front bracket to be pivoted back to properly fit. (See Diagram)
- Measure 4 1/8" on each side of the marked vertical line and mark two more lines on the pinch weld. The dimension between the two outside marked lines should be 8 1/4".
- Measure 3/8" from the inside edge of (pinch weld) the double body metal area at both outside vertical lines and mark two horizontal lines. NOTE: DOUBLE CHECK DIMENSIONS BEFORE DRILLING! (Warning: when drilling holes leave at least 1/8" of metal between the hole and the outside edge of the pinch weld).
- Take a center punch and punch the centers where the two sets of lines cross.
- To finish the installations for Diagrams D & E, follow step 7-19.**

## CARR PATTERN CO., INC.

## WARRANTY POLICY

**FINISHES:** Lifetime

**STRUCTURAL WARRANTY:** Lifetime

### **WARRANTY CONDITIONS:**

a. All warranties start from consumer's date of purchase.

b. A new product will be sent out immediately to replace a warranty claim.

### **WARRANTY LIMITATIONS:**

a. Warranty coverage extends ONLY to repair or replacement of the CARR product. This warranty does not cover the cost of labor, transportation, installation or removal of the product.

b. Warranty coverage does not extend to damage caused by: collision, fire, theft, freezing, vandalism, riot, explosion or object striking the product, or misuse of the product and/or the vehicle on which the product is being installed.

c. Warranty coverage does not extend to damage caused by: airborne fallout (chemicals, tree sap, etc.), stones, hail, earthquake, water of flood, windstorm, lightning, the application of chemicals or sealants subsequent to manufacture.

d. Warranty coverage does not extend to damages caused by: abuse, modification or improper installation of the product.

e. Warranty coverage does not extend to any economic loss or extra expense including (without limitation), payment for the loss of time or pay, inconvenience, storage, loss of vehicle use, vehicle rental expense, equipment rental expense, lodging, meals, or other travel costs.

### **OTHER TERMS:**

a. This warranty gives you specific legal rights and you may also have other rights that vary from state to state. CARR does not authorize any person to create for it any other obligation or liability in connection with its products. ANY IMPLIED WARRANTY OF MERCHANTABILITY OR FITNESS FOR A PARTICULAR PURPOSE APPLICABLE TO THIS PRODUCT IS LIMITED IN DURATION TO THE DURATION OF THIS WRITTEN WARRANTY. PERFORMANCE OF REPAIRS AND NEEDED ADJUSTMENTS IS THE EXCLUSIVE REMEDY UNDER THIS WRITTEN WARRANTY OR ANY IMPLIED WARRANTY. CARR SHALL NOT BE LIABLE FOR INCIDENTAL OR CONSEQUENTIAL DAMAGES RESULTING FROM BREACH OF THIS WRITTEN WARRANTY.\*

\* Some states do not allow limitations on how long an implied warranty will last or the exclusion or limitation of incidental or consequential damages, so the above limitations or exclusions may not apply to you.

**GUARANTEE:** Every attempt has been made to manufacture and distribute the finest quality products available. Our manufactured products are guaranteed to be free of defects due to workmanship or materials. Distributed products are subject to manufacturer's warranty only.