

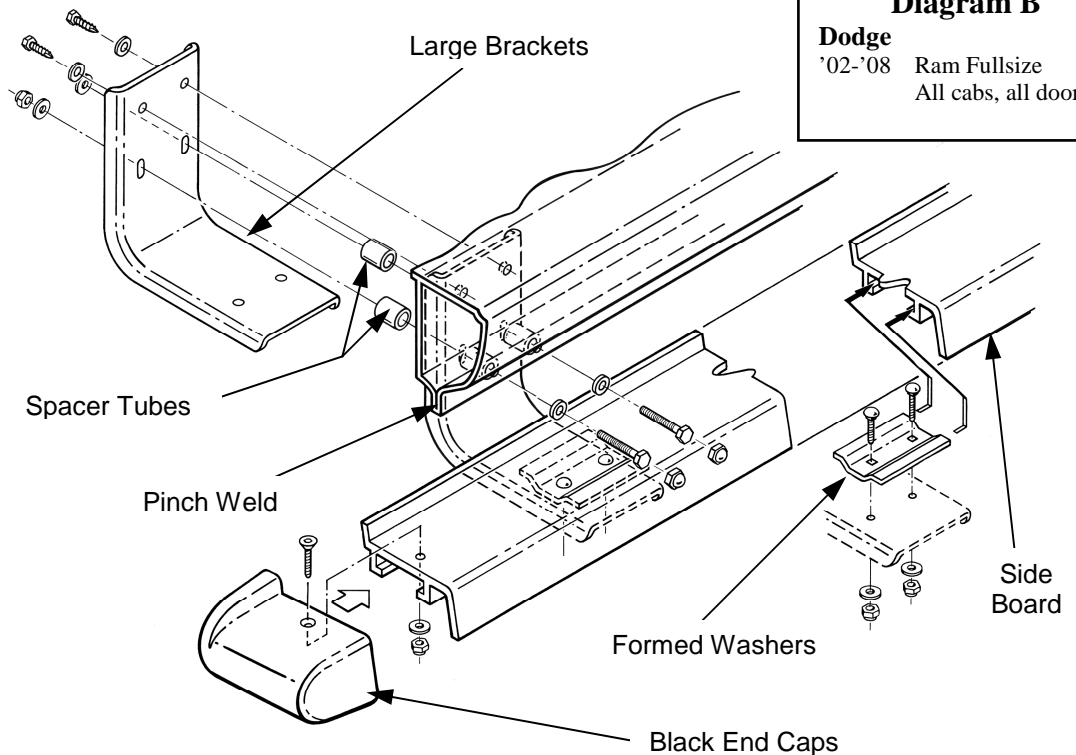

Quality and Style that Endures

Follow the diagram and the written directions carefully for a proper, safe installation.

Should you encounter an unusual, unforeseen problem, contact our Technical Help Line 7:00 AM – 3:00 PM Pacific Time (951) 719-1068 Visit our web-site at www.CARR.com Carr Pattern Co., Inc. 27447 Bostik Court Temecula, CA 92590



1. Depending on the Side Board length, equally space 2 or 3 Large Brackets underneath your truck.
2. Place one of the Large Brackets up against your vehicle as indicated in the drawing. Make sure the Large Bracket is up against a flat surface.
3. Take a pencil and mark a hole through the bottom slots on the Large Bracket on the pinch weld area of your truck. (See Diagram) Center punch the center of the marked hole. IMPORTANT: Make sure when you drill out these holes, do not get too close to the bottom edge of the pinch weld. Make sure there is at least 1/8" thickness from the edge of the pinch weld to the bottom edge of the drilled hole.
4. Take a drill motor with a 3/8" drill bit and drill out the center punched holes. Repeat the above steps for the other Large Brackets.
5. Place the Large Bracket back into place, but this time use the Spacer Tubes between the Large Bracket and the body metal. (See Diagram)
6. Use 5/16" hardware provided and securely tighten Large Bracket to the vehicle. NOTE: Be sure to use black bolts and washers in areas that are visible.
7. Take a drill motor with a 1/8" drill bit and drill through both top holes in the Large Bracket into the body metal. Take a 3/8" wrench and tighten the #14 hex drive sheet metal screws. Repeat the above steps for all the other Large Brackets.
8. Place each Side Board on the Large Brackets. Slide the Side Board forward or backward to center it up with your vehicle. At this point do not use any hardware to secure them to the Large Brackets. NOTE: (Make sure that the Side Boards do not interfere with the front tires when turning)
9. Place the black non-skid diamond Tread Plate, 2 or 4 per vehicle depending on the length of your Side Board, on each Side Board. There are 4 mounting selections to choose from. Select the set of holes that works best with your vehicle. Before installing the Tread Plate, take some clear silicone and run a bead around the back of the Tread Plate. Now place the Tread Plate on the Side Board and take the 1/4" 20 X 3/4" flat head socket screw with the 1/4" washer and nut and securely tighten each Tread Plate. Press down on the Tread Plate. Wipe any excess silicone from around the edges.
10. Place 2 carriage bolts in each Formed Washer. Place 2 or 3 of these assemblies inside the Side Board. (See diagram)
11. Line up the Formed Washer assembly with each Large Bracket and make sure the carriage bolts go through the holes in the Large Brackets.
12. Take the 1/4" washers and hex nuts and tighten the Side Board to the Large Brackets.
13. Carefully tap in place each black End Cap so that the hole in the End Cap lines up with the hole in the Side Board. Take the 1/4" 20 X 1" flat head socket screw with the 1/4" washer and nut and securely tighten each End Cap.
14. Congratulations! Your Enduro Side Boards are now ready to use.

Carr Pattern Co., Inc. Warranty Policy

Finishes: Limited Lifetime

Structural Warranty: Limited Lifetime

Warranty Conditions:

- a. All warranties start from consumer's date of purchase.
- b. A new product will be sent out immediately to replace a warranty claim.
- c. The above guidelines apply only to the Original Purchaser.
- d. Original proof of purchase must be submitted for all warranty and returns issues.

Warranty Limitations:

- a. Warranty coverage extends ONLY to repair or replacement of the CARR product. This warranty does not cover the cost of labor, transportation, installation or removal of the product.
- b. Warranty coverage does not extend to damage caused by: collision, fire, theft, freezing, vandalism, riot, explosion or object striking the product, or misuse of the product and/or the vehicle on which the product is being installed.
- c. Warranty coverage does not extend to damage caused by: airborne fallout (chemicals, tree sap, etc.), stones, hail, earthquake, water or flood, windstorm, lightning, the application of chemicals or sealants subsequent to manufacture.
- d. Warranty coverage does not extend to damages caused by: normal wear and tear, abuse, modification or improper installation of the product.
- e. Warranty coverage does not extend to any economic loss or extra expense including (without limitation), payment for the loss of time or pay, inconvenience, storage, loss of vehicle use, vehicle rental expense, equipment rental expense, lodging, meals, or other travel costs.

Other Terms:

This warranty gives you specific legal rights and you may also have other rights that vary from state to state. CARR does not authorize any person to create for it any other obligation or liability in connection with its products. ANY IMPLIED WARRANTY OF MERCHANTABILITY OR FITNESS FOR A PARTICULAR PURPOSE APPLICABLE TO THIS PRODUCT IS LIMITED IN DURATION TO THE DURATION OF THIS WRITTEN WARRANTY. PERFORMANCE OF REPAIRS AND NEEDED ADJUSTMENTS IS THE EXCLUSIVE REMEDY UNDER THIS WRITTEN WARRANTY OR ANY IMPLIED WARRANTY. CARR SHALL NOT BE LIABLE FOR INCIDENTAL OR CONSEQUENTIAL DAMAGES RESULTING FROM BREACH OF THIS WRITTEN WARRANTY.*

*Some states do not allow limitations on how long an implied warranty will last or the exclusion or limitation of incidental or consequential damages, so that above limitations or exclusions may not apply to you.

Guarantee: Every attempt has been made to manufacture and distribute the finest quality products available. Our manufactured products are guaranteed to be free of defects due to workmanship or materials. Distributed products are subject to manufacturer's warranty only.



CARR Enduro Side Board Installation Instructions

Part No's: 131001-131025 / 132001 & 132003

For Diagrams: A & B



MATERIALS NEEDED: Two 1/2" wrenches, 7/16" wrench, 5/32 Allen wrench, clear silicone (center punch, drill motor, 3/8" drill bit, 1/8" drill bit and pencil – Diagram B only)

MATERIAL FURNISHED: Two Side Boards, four or six Large Brackets, four or six Formed Washers, two or four black Tread Plates, four black End Caps and one hardware pack (**Important! Not all of the parts in this hardware pack may be needed for proper installation.**)

WARNINGS!

- ✓ Do not over tighten the nuts and bolts or damage to the castings and or stripping of the threads could result.
- ✓ FOR SAFE AND PROPER USAGE OF THIS PRODUCT, THE MOUNTING INSTRUCTIONS MUST BE FOLLOWED CAREFULLY AND COMPLETELY.
- ✓ The manufacturer and distributor of this product are in no way responsible for the consumer's failure to adhere to the warnings and directions of these instructions in the event of damage to the consumer's vehicle, other properties and or personal injury.

Diagram A

Ford
'99-'08 Super Duty (All)
All Cabs, all doors

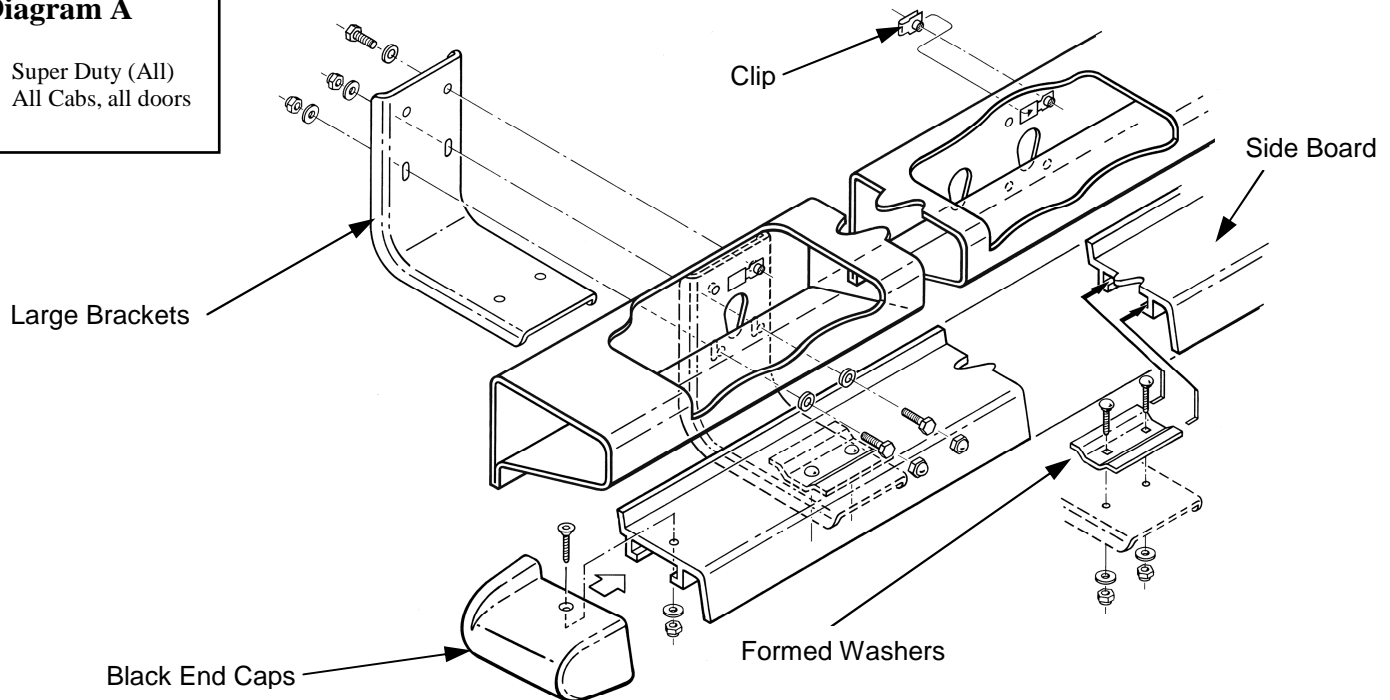

1. Locate the pre-drilled holes underneath your truck. (You may have to remove tape from the rectangular access area)
2. Insert a clip in only 1 top hole for each pre-drilled area. Use 4 or 6 clips per vehicle depending on brackets. (See diagram)
3. Place a Large Bracket in place with the Support Washer under the Large Bracket. Take the 5/16" hardware and secure the Large Bracket and the Support Washer to the vehicle. (See diagram) NOTE: Be sure to use the black bolts and washers in areas that are visible. Take a 5/16" bolt and washer and secure the top hole into the clip.
4. Place each Side Board on the Large Brackets. Slide the Side Board forward or backward to center it up with your vehicle. At this point do not use any hardware to secure them to the Large Brackets. NOTE: (Make sure that the Side Boards do not interfere with the front tires when turning)
5. Place the black non-skid diamond Tread Plate, 2 or 4 per vehicle depending on the length of your Side Board, on each Side Board. There are 4 mounting selections to choose from. Select the set of holes that works best with your vehicle. Before installing the Tread Plate, take some clear silicone and run a bead around the back of the Tread Plate. Now place the Tread Plate on the Side Board and take the 1/4" 20 X 3/4" flat head socket screw with the 1/4" washer and nut and securely tighten each Tread Plate. Press down on the Tread Plate. Wipe any excess silicone from around the edges.
6. Place 2 carriage bolts in each Formed Washer. Place 2 or 3 of these assemblies inside the Side Board. (See diagram)
7. Line up Formed Washer assembly with Large Brackets and make sure the carriage bolts go through the holes in the Large Brackets.
8. Take the 1/4" washers and hex nuts and tighten the Side Board to the Large Brackets.
9. Carefully tap in place each black End Cap so that the hole in the End Cap lines up with the hole in the Side Board. Take the 1/4" 20 X 1" flat head socket screw with the 1/4" washer and nut and securely tighten each End Cap.
10. Congratulations! Your Enduro Side Boards are now ready to use.