

No-Drill Super Hoop Step Mounting Instructions

Part No's: 125001, 125002 & 125004



Quality and Style that Endures

Follow the diagram and the written directions carefully for a proper, safe installation.

Should you encounter an unusual, unforeseen problem, contact our Technical Help Line
7:00 AM – 3:00 PM Pacific Time
(951) 719-1068
Visit our web-site at
www.CARR.com
Carr Pattern Co., Inc.

WARNINGS!

- ✓ Do not over tighten the nuts and bolts or damage to the castings and or stripping of the threads could result.
- ✓ FOR SAFE AND PROPER USAGE OF THIS PRODUCT, THE MOUNTING INSTRUCTIONS MUST BE FOLLOWED CAREFULLY AND COMPLETELY.
- ✓ The manufacturer and distributor of this product are in no way responsible for the consumer's failure to adhere to the warnings and directions of these instructions in the event of damage to the consumer's vehicle, other properties and or personal injury.
- ✓ REFER TO DIAGRAM "A" WIRE HARNESS. STEP "8" ON THIS PAGE MUST BE FOLLOWED, IF NOT ELECTRICAL DAMAGE TO YOUR VEHICLE MAY OCCUR.

Vehicle Application:

FORD

'99-'16 Super Duty all cabs/all doors/all series

MATERIAL NEEDED:

Two 7/16" wrenches, two 1/2" wrenches.

MATERIAL FURNISHED:

Two step castings, four zinc plated steel brackets, one hardware pack and an instruction sheet.

Exploded View of Clip Installation

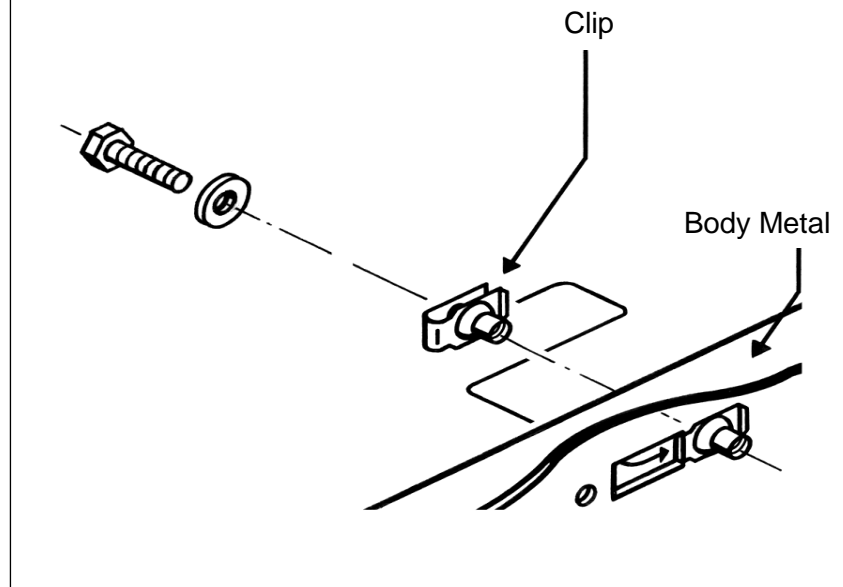

See the other side of this
Instruction for vehicles
installations

WAX YOUR STEP ON A
REGULAR BASIS TO
MAINTAIN ITS LUSTER

Carr Pattern Co., Inc.
Warranty Policy

Finishes: Limited Lifetime

Structural Warranty: Limited Lifetime

Warranty Conditions:

- a. All warranties start from consumer's date of purchase.
- b. A new product will be sent out immediately to replace a warranty claim.
- c. The above guidelines apply only to the Original Purchaser.
- d. Original proof of purchase must be submitted for all warranty and returns issues.

Warranty Limitations:

- a. Warranty coverage extends ONLY to repair or replacement of the CARR product. This warranty does not cover the cost of labor, transportation, installation or removal of the product.
- b. Warranty coverage does not extend to damage caused by: collision, fire, theft, freezing, vandalism, riot, explosion or object striking the product, or misuse of the product and/or the vehicle on which the product is being installed.
- c. Warranty coverage does not extend to damage caused by: airborne fallout (chemicals, tree sap, etc.), stones, hail, earthquake, water or flood, windstorm, lightning, the application of chemicals or sealants subsequent to manufacture.
- d. Warranty coverage does not extend to damages caused by: normal wear and tear, abuse, modification or improper installation of the product.
- e. Warranty coverage does not extend to any economic loss or extra expense including (without limitation), payment for the loss of time or pay, inconvenience, storage, loss of vehicle use, vehicle rental expense, equipment rental expense, lodging, meals, or other travel costs.

Other Terms:

This warranty gives you specific legal rights and you may also have other rights that vary from state to state. CARR does not authorize any person to create for it any other obligation or liability in connection with its products. ANY IMPLIED WARRANTY OF MERCHANTABILITY OR FITNESS FOR A PARTICULAR PURPOSE APPLICABLE TO THIS PRODUCT IS LIMITED IN DURATION TO THE DURATION OF THIS WRITTEN WARRANTY. PERFORMANCE OF REPAIRS AND NEEDED ADJUSTMENTS IS THE EXCLUSIVE REMEDY UNDER THIS WRITTEN WARRANTY OR ANY IMPLIED WARRANTY. CARR SHALL NOT BE LIABLE FOR INCIDENTAL OR CONSEQUENTIAL DAMAGES RESULTING FROM BREACH OF THIS WRITTEN WARRANTY.*

*Some states do not allow limitations on how long an implied warranty will last or the exclusion or limitation of incidental or consequential damages, so that above limitations or exclusions may not apply to you.

Guarantee: Every attempt has been made to manufacture and distribute the finest quality products available. Our manufactured products are guaranteed to be free of defects due to workmanship or materials. Distributed products are subject to manufacturer's warranty only.

CARR • 27447 Bostik Court • Temecula CA 92590



Super Hoop Multi-Mount Step Installation Instructions

Part No's: 125001, 125002 & 125004

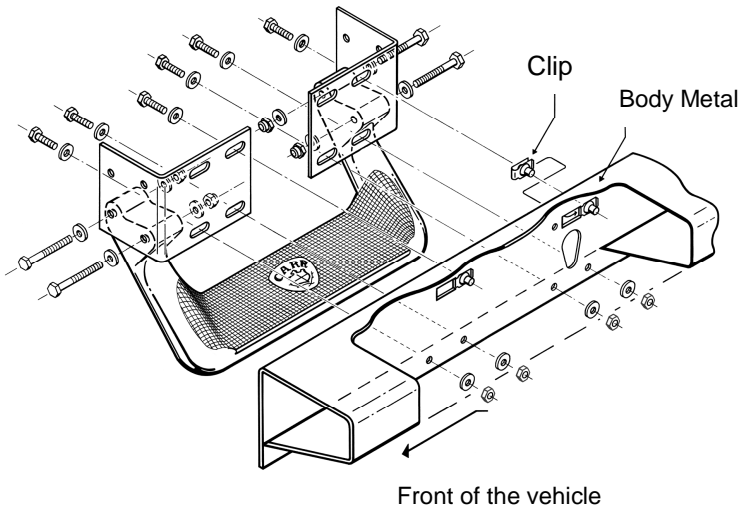

DIAGRAM FOR:
Front door ALL CABS.
Drivers side shown here

1. Place the steel brackets on the step casting the same way as shown on the diagram.
2. Securely tighten the steel brackets to the step casting with the 1/4" hardware provided.
3. Install the clips as shown here by pushing the clips to the side. (A larger view of the clips installation is available on the reverse side of this sheet).
4. Take the 5/16" hardware that is provided and bolt the step and bracket assembly to the truck under the front door using the holes in the truck as indicated on the diagram.
5. Repeat the same procedure for the passenger side of your vehicle.

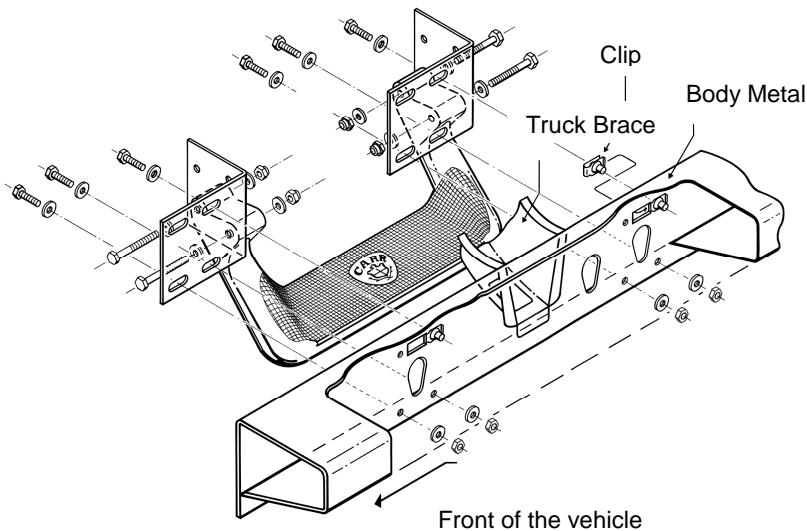

DIAGRAM FOR:
Rear door EXTENDED CAB.
Drivers side shown here

1. Place the steel brackets on the step casting the same way as shown on the diagram.
2. Securely tighten the steel brackets to the step casting with the 1/4" hardware provided.
3. Install the clips as shown here by pushing the clips to the side. (A larger view of the clips installation is available on the reverse side of this sheet).
4. Take the 5/16" hardware that is provided and bolt the step and bracket assembly to the truck under the rear door using the holes in the truck as indicated on the diagram.
5. Repeat the same procedure for the passenger side of your vehicle only reverse how the steel brackets bolt to the step casting.

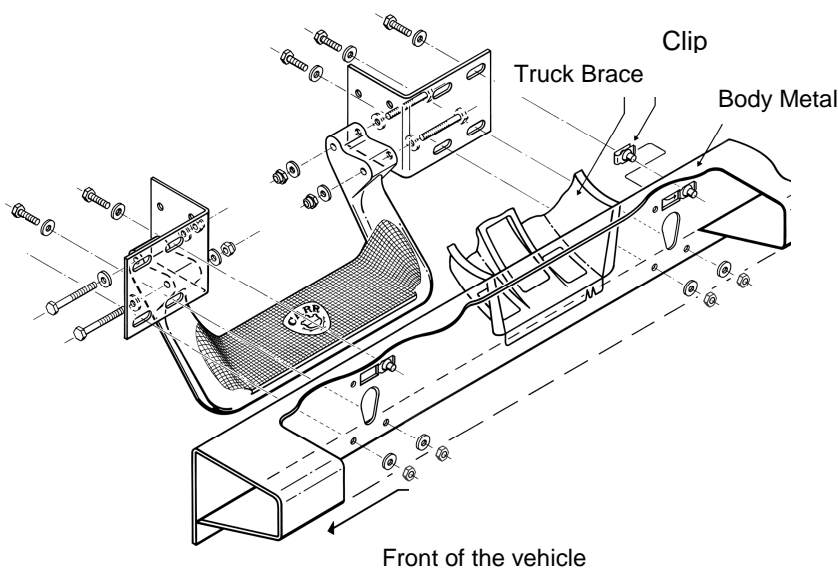

DIAGRAM FOR:
Rear door CREW CAB.
Drivers side shown here

1. Place the steel brackets on the step casting the same way as shown on the diagram.
2. Securely tighten the steel brackets to the step casting with the 1/4" hardware provided.
3. Install the clips as shown here by pushing the clips to the side.. (A larger view of the clips installation is available on the reverse side of this sheet).
4. Take the 5/16" hardware that is provided and bolt the step and bracket assembly to the truck under the rear door using the holes in the truck as indicated on the diagram.
5. Repeat the same procedure for the passenger side of your vehicle only reverse how the steel brackets bolt to the step casting.