

HOOP II MULTI-MOUNT STEP INSTALLATION INSTRUCTIONS

Part No.'s: 102561, 102562 & 102564



WARNING: Do not over tighten nuts and bolts, or damage to the casting and or stripping of the threads could result.

WARNING: FOR SAFE AND PROPER USAGE OF THIS PRODUCT, THE MOUNTING INSTRUCTIONS MUST BE FOLLOWED CAREFULLY AND COMPLETELY.

IMPORTANT: The manufacturer and distributor of this product are in no way responsible for the consumer's failure to adhere to the warnings and directions of these instructions, in the event of damage to the consumer's vehicle, other properties and or personal injury.

ITS PAINTABLE

All of the bright finished products can be painted to whatever color you like. Simply sand your bright finished step lightly all over, prime it with "Synthetic Zinc Chromate Primer", let dry, and it's ready to paint.

Materials Needed:

Phillips screwdriver, pencil, center punch, drill motor, sharp 1/8" drill bit, sharp 5/16" drill bit, 10mm socket and socket wrench, 2 1/2" open or box end wrenches, rags.

Materials Furnished:

Two Hoop II Steps, Four Mount Feet, Four Steel Brackets, Two Hardware Packs, Instruction.

STANDARD VERTICAL MOUNT

CHEVY / GMC

'92-'99 SUBURBAN / '92-'99 YUKON/TAHOE

DRIVER'S SIDE SHOWN

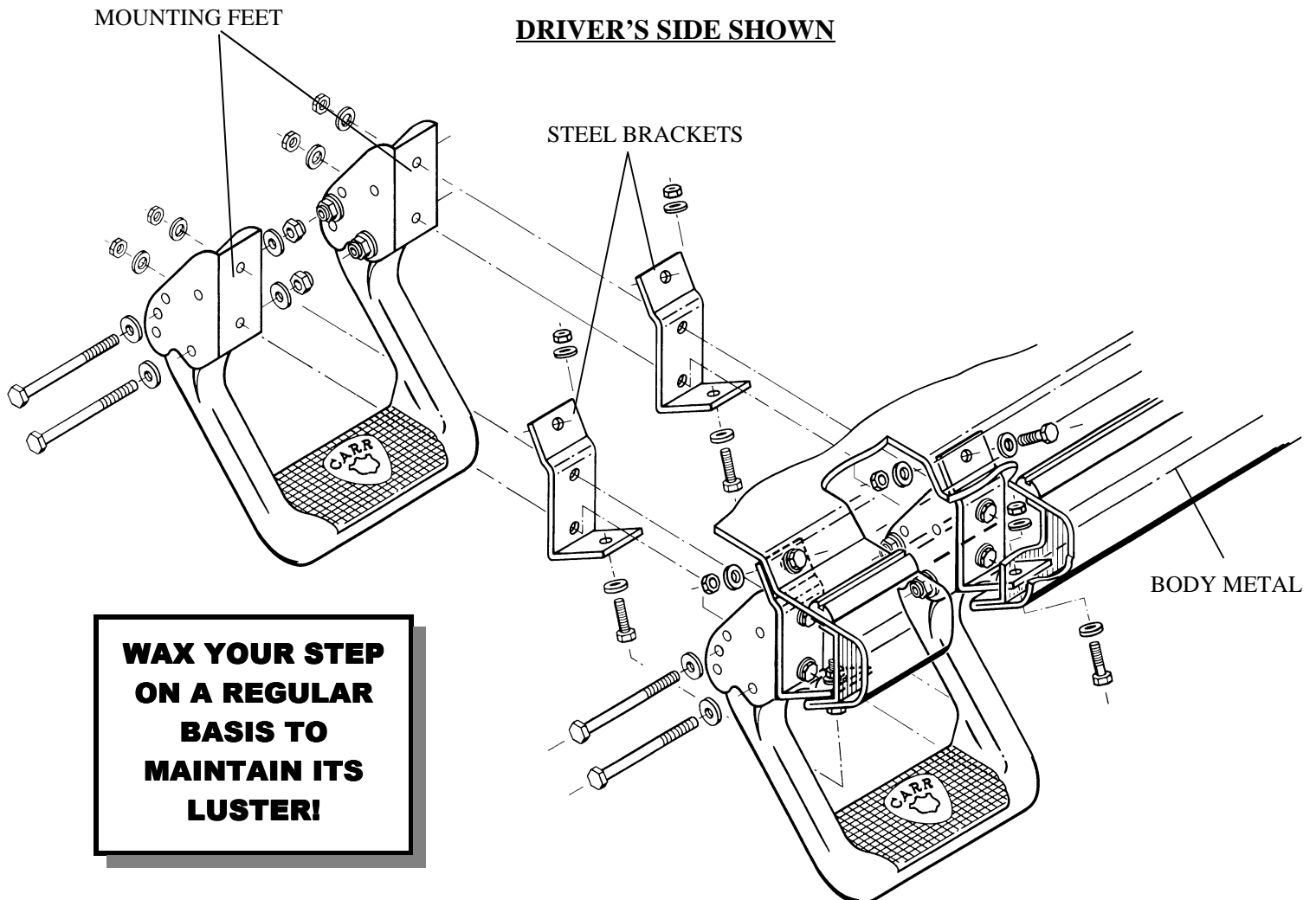

HOOP II MULTI-MOUNT STEP INSTALLATION INSTRUCTIONS

Part No.'s: 102561, 102562 & 102564



WARNING: Do not over tighten nuts and bolts, or damage to the casting and or stripping of the threads could result.

WARNING: FOR SAFE AND PROPER USAGE OF THIS PRODUCT, THE MOUNTING INSTRUCTIONS MUST BE FOLLOWED CAREFULLY AND COMPLETELY.

IMPORTANT: The manufacturer and distributor of this product are in no way responsible for the consumer's failure to adhere to the warnings and directions of these instructions, in the event of damage to the consumer's vehicle, other properties and or personal injury.

ITS PAINTABLE

All of the bright finished products can be *paint*ed to whatever color you like. Simply sand your bright finished step lightly all over, prime it with "Synthetic Zinc Chromate Primer", let dry, and it's ready to *paint*.

1. Remove all of the plastic carpet covers at the door jam before starting. Refer to diagram 1. **ELECTRICAL CAUTION: The passenger side has an electrical wire harness underneath the plastic carpet cover. The wire harness is protected by a plastic cover. However, when drilling, be very careful not to drill through the plastic cover into the wire harness.**
2. Assemble the Mounting Feet to the step as shown in the Master drawing, but only hand tighten.
3. Take **only two** steel brackets with the hardware provided (be sure only to use the 5/16" bolts provided) and bolt each steel bracket to each mounting foot. Tap each steel bracket into position until the steel brackets are straight on each mounting foot. (Refer to diagram 2)

Diagram 1

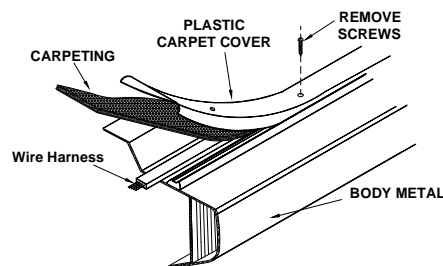

4. On the passenger side only, there are air-conditioning lines and rear heater lines on the bottom inside face of the rocker panel that run along the length of both doors. (Refer to diagram 3). There are four rubber clamping brackets that hold all four lines in place. Take a 10mm socket and socket wrench and back out the screws **ONLY** half way to loosen the lines up. NOTE: (If the screws are removed, they will be extremely difficult to reinstall.)

Diagram 2

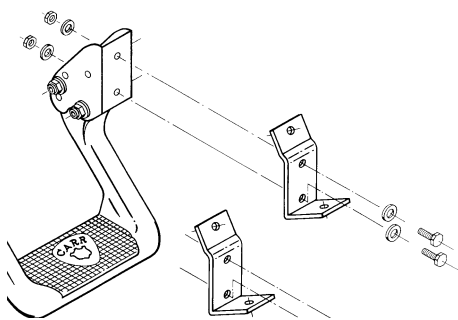

5. From underneath your vehicle, place your step in desired position with the feet of the steel brackets laying on top of the pinch weld. You may have to slightly

move your step forward or backward to avoid the rubber clamping brackets and the front body mount.

6. While securely holding the step in place, mark the top hole of each steel bracket and mark lines all along each side of the steel bracket on the body metal. Remove the step from underneath the vehicle.
7. Center punch the two top marked holes. (**REFER TO THE ELECTRICAL CAUTION ABOVE!**) Take a drill motor and a sharp 1/8" drill bit and drill out the center punched holes. Go back with a sharp 5/16" drill bit and enlarge the 1/8" holes. (Caution: do not allow the drill to wander when drilling. This will result in a mis-alignment of the drilled holes.)

Diagram 3

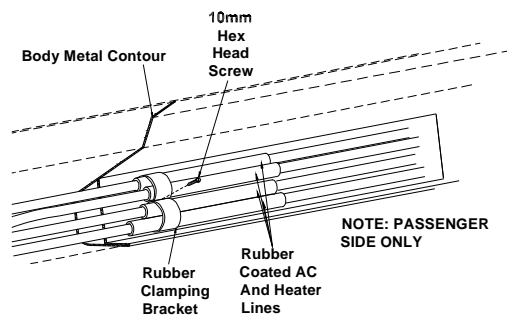

HOOP II MULTI-MOUNT STEP INSTALLATION INSTRUCTIONS

Part No.'s: 102561, 102562 & 102564



WARNING: Do not over tighten nuts and bolts, or damage to the casting and or stripping of the threads could result.

WARNING: FOR SAFE AND PROPER USAGE OF THIS PRODUCT, THE MOUNTING INSTRUCTIONS MUST BE FOLLOWED CAREFULLY AND COMPLETELY.

IMPORTANT: The manufacturer and distributor of this product are in no way responsible for the consumer's failure to adhere to the warnings and directions of these instructions, in the event of damage to the consumer's vehicle, other properties and or personal injury.

ITS PAINTABLE

All of the bright finished products can be painted to whatever color you like. Simply sand your bright finished step lightly all over, prime it with "Synthetic Zinc Chromate Primer", let dry, and it's ready to paint.

- *8. Take an unused steel bracket and place in the same spot as where the drilled hole and lines are. (Also note Step 24)
9. Put one of the 5/16" bolts through the body metal from the open door side and through the steel bracket. Line up the bracket with the marked lines. Mark two more lines on the outside of the pinch weld that line up with the lines inside of the pinch weld. Also, using the edge of the pinch weld as a guide, mark another line across the bottom of the foot of the steel bracket (refer to diagram 4).
10. Take the 5/16 bolt out and remove the steel bracket. Measure the distance from the marked line across the foot of the steel bracket and the center of the hole.
11. Take the dimension from step 10 and measure the same distance from the pinch weld. Mark a line on the body metal centered between the other outside lines.
12. Measure across the outside lines and mark another line that will cross the line you marked in Step 11.
13. Center punch where the lines cross.
14. Stuff a rag between the body metal and the A/C and rear heater lines to push the lines up out of the way while drilling.
15. Before drilling, take the steel bracket and slip it between the body metal and the A/C and rear heater lines for protection when drilling.
16. With a sharp 1/8" drill bit, drill out the center punched area. Go back and drill out the 1/8" hole with a 5/16" drill bit.
17. Place the steel bracket back into place. Put a 5/16" bolt in both holes to see if the holes in the body metal line up with the holes in the steel bracket. If the holes do not line up, take a round file or a power grinder and enlarge the hole until the bolts fit.
18. Repeat the steps for drilling out the holes for the other steel bracket.
19. With all the holes drilled, place your step back into position. Use the 5/16" hardware provided and hand tighten the front steel bracket to the vehicle. (Refer to Diagram 5).
20. Take additional hardware and hand tighten the rear steel bracket to the vehicle. NOTE: if the rear bracket holes do not line up, loosen the bolts on mounting foot. This should give enough play to get the holes to line up.
21. With everything in its proper place, go back and securely tighten all the hardware.

Diagram 4

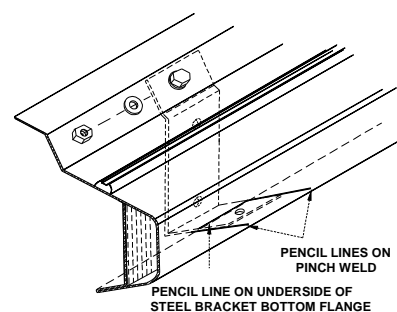
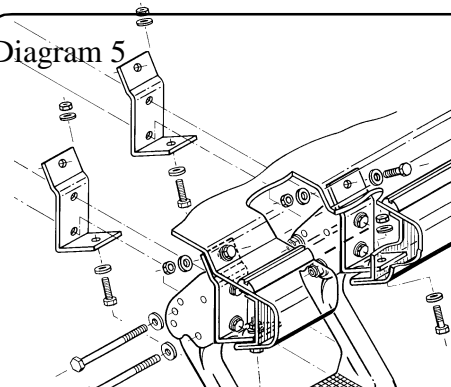

Diagram 5



HOOP II MULTI-MOUNT STEP INSTALLATION INSTRUCTIONS

Part No.'s: 102561, 102562 & 102564

WARNING: Do not over tighten nuts and bolts, or damage to the casting and or stripping of the threads could result.

WARNING: FOR SAFE AND PROPER USAGE OF THIS PRODUCT, THE MOUNTING INSTRUCTIONS MUST BE FOLLOWED CAREFULLY AND COMPLETELY.

IMPORTANT: The manufacturer and distributor of this product are in no way responsible for the consumer's failure to adhere to the warnings and directions of these instructions, in the event of damage to the consumer's vehicle, other properties and or personal injury.

ITS PAINTABLE

All of the bright finished products can be painted to whatever color you like. Simply sand your bright finished step lightly all over, prime it with "Synthetic Zinc Chromate Primer", let dry, and it's ready to paint.

22. Remove the rags used for drilling.
23. Tighten the loosened screws on the rubber clamps for the A/C and rear heater lines.
- *24. Follow the same steps for installing the other step on the driver's side of the vehicle. However, since there are none, skip over all directions that refer to A/C and rear heater lines. *Also, after drilling out the top holes on the body metal for the steel brackets and checking to see if they line up, take one steel bracket off of one mounting foot and use it for marking your lines and lining up the holes to be drilled. (Also see step 8)
25. It is a good idea to take some silicone and seal around the areas drilled into the body metal.
26. That's all there's to it! Now your step is ready for use.
27. **To maintain the shine and luster of your step, we recommend to wax it with a good quality aluminum wax. (For XM3 finish only).**



Quality and Style that Endures

Follow the Diagrams and the Written Directions on the back carefully for a proper, safe installations.

Should you encounter an unusual, unforeseen problem, contact our Technical Help Line

7:00 AM - 3:00 PM

Pacific Time

(951) 719-1068

www.CARR.com

©CARR PATTERN CO., INC.

**FOR A DEALER NEAREST YOU, CALL:
1-888-OWN CARR (1-888-696-2277)**

CARR PATTERN CO., INC.

WARRANTY POLICY

FINISHES: Lifetime

STRUCTURAL WARRANTY: Lifetime

WARRANTY CONDITIONS:

- a. All warranties start from consumer's date of purchase.
- b. A new product will be sent out immediately to replace a warranty claim.

WARRANTY LIMITATIONS:

- a. Warranty coverage extends ONLY to repair or replacement of the CARR product. This warranty does not cover the cost of labor, transportation, installation or removal of the product.
- b. Warranty coverage does not extend to damage caused by: collision, fire, theft, freezing, vandalism, riot, explosion or object striking the product, or misuse of the product and/or the vehicle on which the product is being installed.
3. Warranty coverage does not extend to damage caused by: airborne fallout (chemicals, tree sap, etc.), stones, hail, earthquake, water of flood, windstorm, lightning, the application of chemicals or sealants subsequent to manufacture.
4. Warranty coverage does not extend to damages caused by: abuse, modification or improper installation of the product.
5. Warranty coverage does not extend to any economic loss or extra expense including (without limitation), payment for the loss of time or pay, inconvenience, storage, loss of vehicle use, vehicle rental expense, equipment rental expense, lodging, meals, or other travel costs.

OTHER TERMS:

a. This warranty gives you specific legal rights and you may also have other rights that vary from state to state. CARR does not authorize any person to create for it any other obligation or liability in connection with its products. ANY IMPLIED WARRANTY OF MERCHANTABILITY OR FITNESS FOR A PARTICULAR PURPOSE APPLICABLE TO THIS PRODUCT IS LIMITED IN DURATION TO THE DURATION OF THIS WRITTEN WARRANTY. PERFORMANCE OF REPAIRS AND NEEDED ADJUSTMENTS IS THE EXCLUSIVE REMEDY UNDER THIS WRITTEN WARRANTY OR ANY IMPLIED WARRANTY. CARR SHALL NOT BE LIABLE FOR INCIDENTAL OR CONSEQUENTIAL DAMAGES RESULTING FROM BREACH OF THIS WRITTEN WARRANTY.*

* Some states do not allow limitations on how long an implied warranty will last or the exclusion or limitation of incidental or consequential damages, so the above limitations or exclusions may not apply to you.

GUARANTEE: Every attempt has been made to manufacture and distribute the finest quality products available. Our manufactured products are guaranteed to be free of defects due to workmanship or materials. Distributed products are subject to manufacturer's warranty only.

CARR - 27447 BOSTIK COURT - TEMECULA - CA - 92590